

**ECO STRIP LIGHTS**

**3 COLOR PREFERENCE®**

1100 - 2101 Delivered Lumens | Efficacy up to 135

**KEY FEATURES**

Each luminaire is equipped with easy end-to-end connection features, and have 3 field selectable color temperature options—3000K, 4000K and 5000K.

**CCT & Light Quality**

- 3 Selectable CCTs (3000, 4000, 5000)
- CRI up to 86

**Light Output & Efficacy**

- High Lumen Output: 1100 – 1174 lumens (2')  
1983 – 2101 lumens (4')
- Efficacy Rating:  
**2 FT:** 120 – 135 | **4 FT:** 118 – 129
- Reported L91/54,000, Projected L70 @ 171,000 hours (min shown per IES TM21); 89.58% LED lumen maintenance at 54,000 hours

**Dimming, Voltage**

- TRIAC dimming | 120V

**SPECIFICATIONS**

**Construction**

- Formed steel housing
- Post painted with reflective paint for ease of handling

**Optics**

- Non-yellowing PC lens material provides high light transmittance
- Semi-diffused, frosted, 1 mm thick secondary polymer lens. provides a uniform and soft visual appearance when in direct view with minimal LED pixelation and reduces glare

**Installation**

- Comes with suspension mounting kit
- Surface mounting kit accessory available (sold separately)
- Easy end-to-end connection capabilities:

*End-to-End Connector Included*  
*Linking cord accessory available (sold separately)*

- 3CCT COLOR PREFERENCE® for easy field-adjustable CCT selection. Factory set to 3000K.

**Electrical**

- 171,000 hour LEDs at L70 for reduced maintenance
- Operates at 120V, 60 Hz | TRIAC dimming down to 10%
- BBU field installed accessories available

**Warranty**

5-Year Standard Warranty. See terms at: [ETISSL.com/warranty/](https://ETISSL.com/warranty/)

KEY DATA	
Lumen Range	1100 – 2101
Wattage Range	8.7 – 17.2
Efficacy Range (LPW)	118 – 135
Reported Life (Hours)	L70 / 143,000

DATE:	PROJECT:
TYPE:	NOTES:
CATALOG #:	



4' Strip

2' Strip

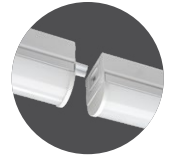

End-to-End Connector Included

**Certifications & Test Data**

- All luminaires are UL listed and are built for damp location use
- Adheres to LM79, and TM30 industry standards for photometric, lumen maintenance and lifetime calculations
- DLC® (DesignLights Consortium) Qualified. Please refer to DLC for specific product qualifications at [www.designlights.org](http://www.designlights.org) (See Page 4 for search info.)
- Driver rated for FCC part 15 Class B for use in residential or commercial applications
- Suitable for use in closets when installed in accordance with NEC Section 410.16 (A)(1)(3) and 410.16 (C)(1)(3)(5)



**CATALOG LOGIC**

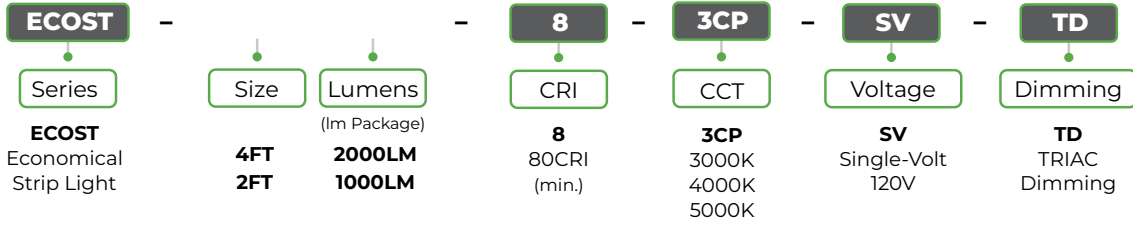

**STOCK ORDERING INFORMATION** (typical 2-3 day shipment lead time)<sup>1</sup>

Catalog Part Number	Order Number	Description (Dia)	Case QTY	CRI	CCT (3CP)	Watts (Nom.)	Lumen Pkg	Delivered Lumens	Efficacy (LPW)	Volt.	Dim	DLC
ECOST-4FT-2000LM-8-3CP-SV-TD	556091110	4' Strip Light	4	80+	3000K	17	2000	2028	118	120V	TRIAC	Standard Search: 556091###
					4000K	17	2000	2101	129			
					5000K	17	2000	1983	118			
ECOST-2FT-1000LM-8-3CP-SV-TD	556081110	2' Strip Light	6	80+	3000K	8.5	1000	1100	120	120V	TRIAC	Standard Search: 556081###
					4000K	8.5	1000	1174	135			
					5000K	8.5	1000	1107	123			

Notes: 1. Stock SKUs typically ship in 24-48 hours upon receipt of an approved released order  
 2. For more delivered lumens and test data see pages 3, or visit ETISSL.com

**AVAILABLE STOCK ACCESSORIES** (must be ordered separately, field installed)

**Emergency LED Driver/BBU<sup>2</sup>** ⚠️ **Not compatible with Motion Sensor**

Order Number	Description	Details
70112202-2 (EMA25FY-170)	Square Emergency LED Driver BBU 25W, IP rated, 90 min	 BBU's certified in CA Title 20 MAEDBS. Search: EMA25FY-170 <a href="#">SPEC SHEET DOWNLOAD</a> (located on ETISSL.com)

Notes: 1. Also compatible with: 70114402-2 (40W, IP rated, 90 minutes, Square)  
 2. BBU's CANNOT be used or installed with Motion Sensor. Luminaire can be used with either BBU or Sensor. It is not compatible with both.

**Motion Sensor<sup>1</sup>** ⚠️ **Not compatible with Emergency LED Driver/BBU**

Order Number	Description	Details
90600121	Multi-Volt Occupancy Sensor with daylight sensor, (External)	 <a href="#">SPEC SHEET DOWNLOAD</a> (located on ETISSL.com)

Notes: 1. Motion Sensor CANNOT be used or installed with BBU's. Luminaire can be used with either BBU or Sensor. It is not compatible with both.

**Mounting Accessories<sup>2</sup>** (order separately, field installed)

Order Number	Description	Details
54657102	4" J-Box Surface Mounting Plate and Screws	 <a href="#">PRODUCT LISTING</a> (located on ETISSL.com)

**DIMENSIONS / DETAILS**

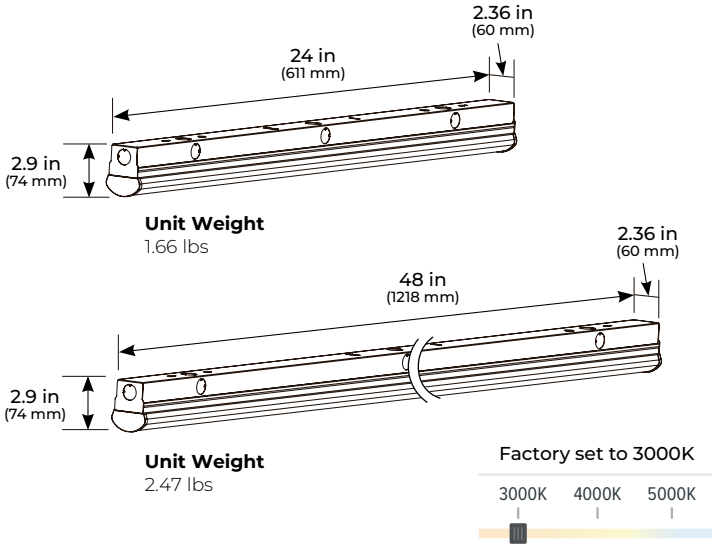

**MOUNTING**

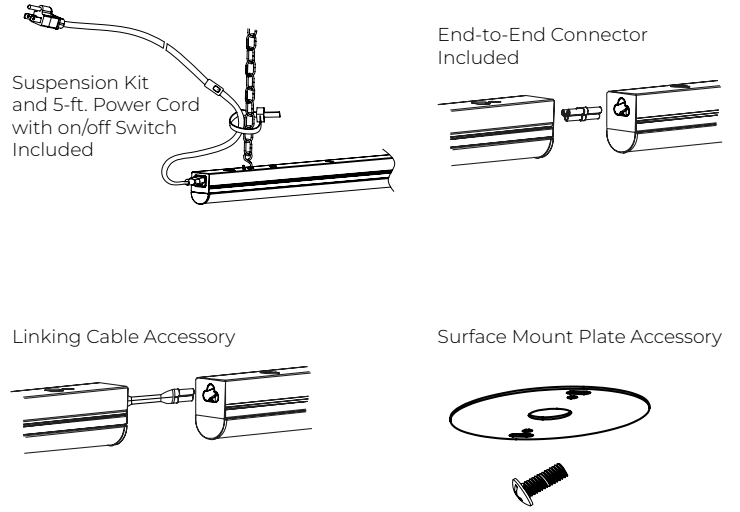

**PERFORMANCE / Data**

**Lumen Maintenance**

Ambient Temp.	TM-21 Lumen Maintenance (54,000 hours)
25° C (77° F)	> 89,58%
Ambient Temp.	TM-21 Theoretical L70 (hours)
25° C (77° F)	171,000

**Load Information**

<b>Power Factor</b>	0.90
<b>THD</b>	< 20%
<b>Frequency</b>	60 Hz
<b>Sound Rating</b>	< 20 Dba
<b>Low Temp Start / Max Temp</b>	-20° C (-4° F) / 40° C (104° F)

**PHOTOMETRIC SAMPLES**

2-FT

**Luminaire Data: 2' at 4000K**

CCT & CRI	<b>4000K, 86 CRI</b>
Initial Delivered Lumens	<b>1174</b>
Wattage	<b>8.7W</b>
Efficacy	<b>135</b>
Spacing	<b>0° = 1.26 90° = 1.36</b>

Photometric values based on tests performed in compliance with LM-63 & LM-79

**Indoor Candela Plot**

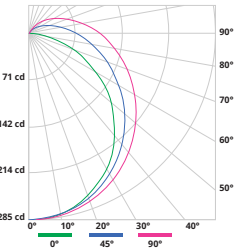

4-FT

**Luminaire Data: 4' at 4000K**

CCT & CRI	<b>4000K, 86 CRI</b>
Initial Delivered Lumens	<b>2101</b>
Wattage	<b>16.3W</b>
Efficacy	<b>128.75</b>
Spacing	<b>0° = 1.26 90° = 1.36</b>

Photometric values based on tests performed in compliance with LM-63 & LM-79

**Indoor Candela Plot**

