

# LED OUTDOOR EMERGENCY LIGHT

## INSTALL INSTRUCTIONS



PLEASE READ THE INSTRUCTIONS BEFORE INSTALLING AND/OR OPERATING EMERGENCY LIGHT

### SAFETY CAUTIONS

ALL ELECTRICAL CONNECTIONS MUST BE IN ACCORDANCE WITH LOCAL AND NATIONAL ELECTRICAL CODE (N.E.C.) STANDARDS. IF YOU ARE UNFAMILIAR WITH PROPER ELECTRICAL WIRING CONNECTIONS OBTAIN THE SERVICES OF A QUALIFIED ELECTRICIAN.

- Review diagrams thoroughly before installation.
- Disconnect power at fuse or circuit breaker before installing or servicing.
- Do not mount in hazardous locations, or near gas or electrical heaters.
- Do not let power cords touch hot surface.
- Equipment should be mounted in locations where it will not be readily subject to tampering by unauthorized personnel.
- The use of accessory equipment not recommended by the original manufacturer may cause an unsafe operating condition.
- Do not use this equipment for other than intended use.
- Servicing of this equipment should be performed by qualified service personnel.
- Allow battery to charge for 24 hours before first use.

PLEASE SAVE THESE INSTRUCTIONS

**! WARNING** DISCONNECT POWER BEFORE INSTALLING OR SERVICING.

### DESCRIPTION (Fig. 1)

1. Photo Sensor
2. LED Light
3. Cable Outlet
4. Test Button & Two-Color Function Indication

### MOUNTING

1. Remove cover from the fixture with a screw driver. (Fig. 2)
2. Select working mode. (Fig. 3)
3. Make the proper supply wire connections. Connect L and N to building power supply.
4. Pull out all AC wires from the back of the fixture (J-box not provided) or top of the fixture for mounting. (Fig. 4)
5. Restore power and press test button. AC light will turn off.

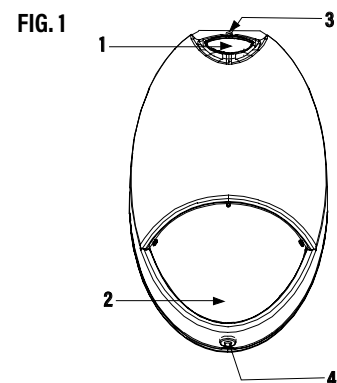

FIG. 2

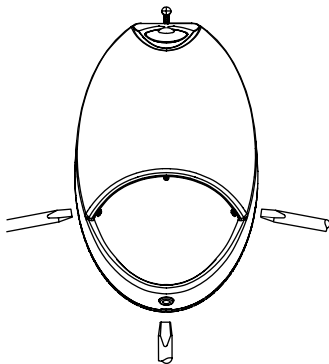

FIG. 3

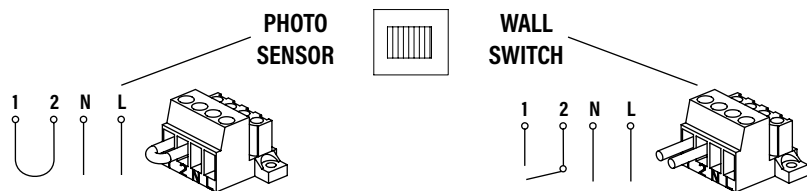
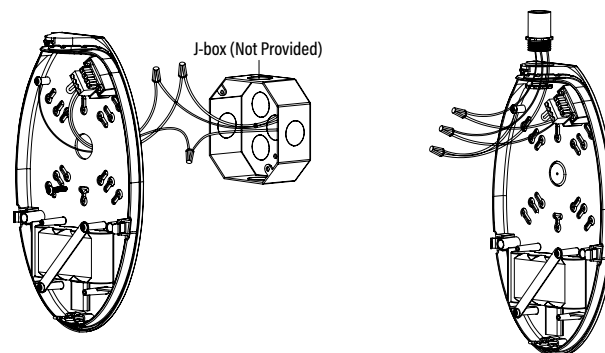

FIG. 4



# LED OUTDOOR EMERGENCY LIGHT

## INSTALL INSTRUCTIONS



**WARNING** DISCONNECT POWER BEFORE INSTALLING OR SERVICING.

### FUNCTION

- When AC is connected, the green indicator will be on.
- The fixture can be configured for automatic operation by the built-in daylight photo sensor, or can be switched through an external switch. For battery backup models the fixture will illuminate from the battery power on loss of normal AC, regardless of the photo sensor or wall switch operation.
  - Photo Sensor operation:** connect the jumper between terminals 1 and 2 (Fig. 5) and slide the slide switch (Fig. 7) to the Photo Sensor position. The photo sensor will turn the fixture on when the ambient lighting <10 Lux, and off when the ambient lighting >30 Lux.
  - External Switch operation:** remove the jumper between terminals 1 and 2 (Fig. 6), and slide the slide switch (Fig. 7) to the Wall Switch position. The external switch connections must be fully isolated from any other circuitry.

FIG. 5 - Photo Sensor Operation

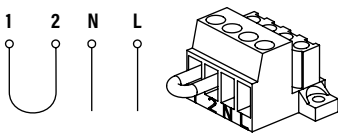

FIG. 6 - External Switch Operation

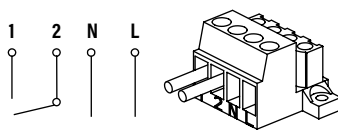
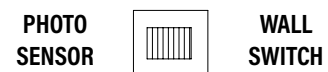

FIG. 7 - Slide Selector Switch



### AUTOMATIC TESTING

- Install Emergency Lighting according to instructions on Page 1.
- Once AC power is supplied to fixture, the unit will automatically initiate a self-test and self-diagnostic test as follows:
  - Verify battery disconnection, charger failure, transformer failure at every 5 seconds.
  - One-Minute self-testing (battery discharging test) every month.
  - 30 minutes self-testing (battery discharging test) on the 6th month of the year.
- Dual color LED lamp shows the following status:
  - Green Color (Operating Status)
  - Red Color (Service Alert)
  - Service Alert LED Code (Red color LED Lamp)

Blinks		Code
●	One Blink ON/Pause (4 Seconds)	Battery is not connected
●●	Two Blinks ON/Pause (4 Seconds)	Battery is shorted or battery voltage drops below an acceptable value
●●●	Three Blinks ON/Pause (4 Seconds)	Charger board circuit fault
●●●●	Four Blinks ON/Pause (4 Seconds)	Transformer fault

For manual test, press test button as follows:	
Press test button once (Within 2 seconds)	1 Minute Test
Press test button twice (Within 2 seconds)	5 Minute Test
Press test button 3 times (Within 2 seconds)	30 Minute Test
Press test button 4 times (Within 2 seconds)	90 Minute Test

### IMPORTANT

After correcting a service alert fault, it is necessary to depress the test button for 2 seconds. Once released the LED indicator will be green if all faults have been corrected.